

SHARPE

THE SPRAY GUN PEOPLE[®]

AIR CONTROL UNITS

Maximum Working Pressure: 160 psi (1.1 MPa, 11 bar)

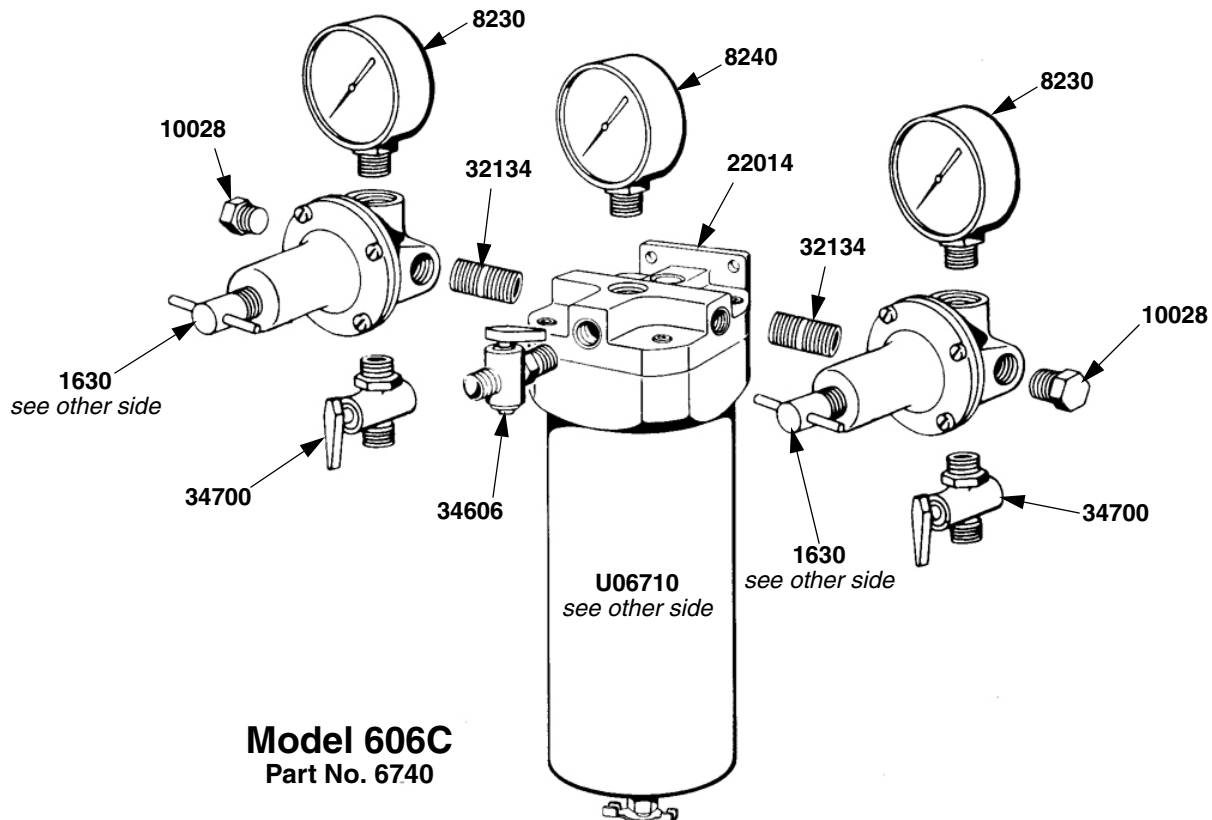
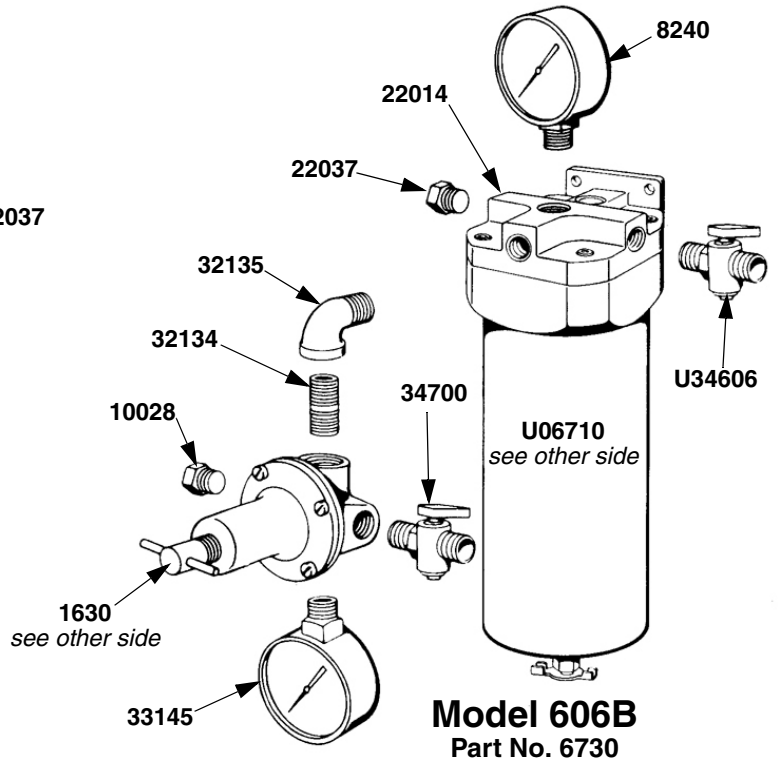
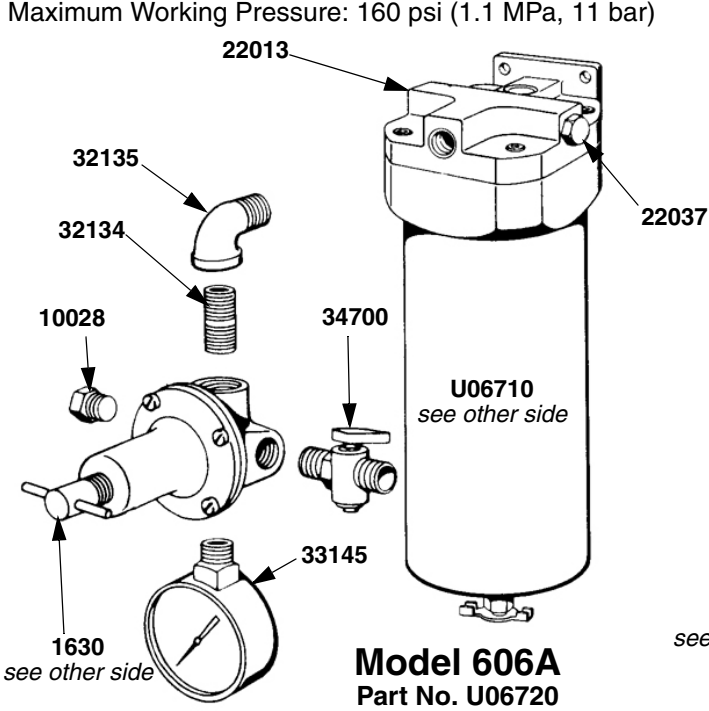

Model 606 AIR FILTER

Part No. 6710

Model 606 Air Filter

Maximum Working Pressure:
160 psi (1.1 MPa, 11 bar)

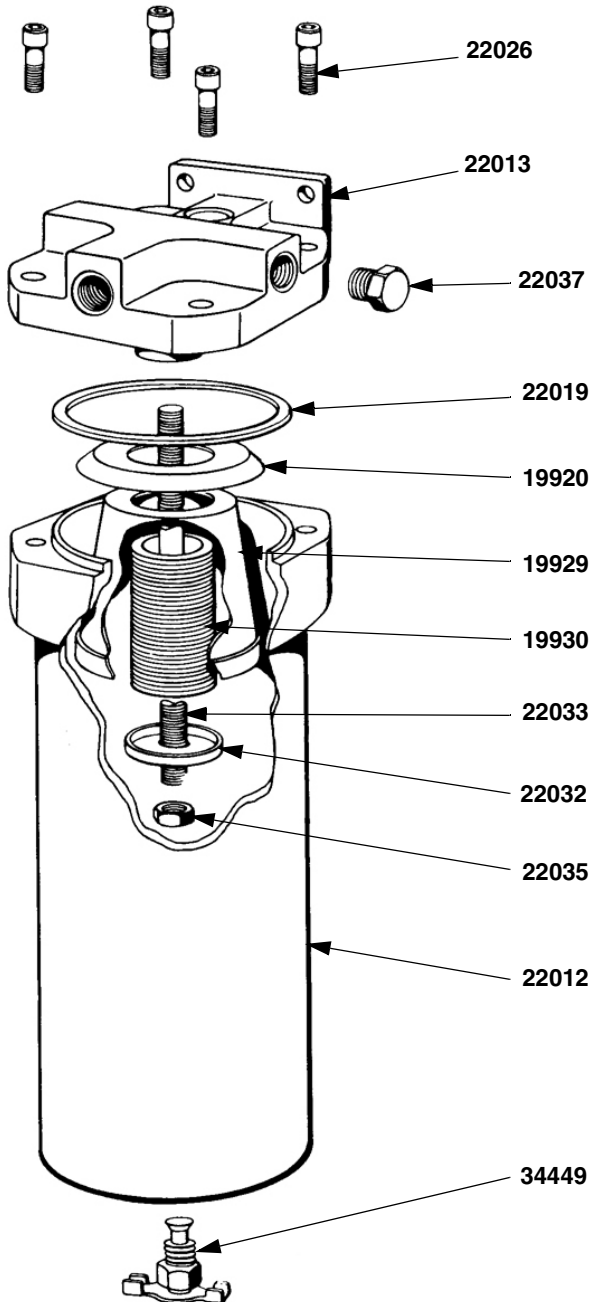

PART NO.	DESCRIPTION
22026	Screw
22013	Bottle Lid
22037	Plug
22019	Gasket
19920	Washer
19929	Shield
19930	Filter Element
22033	Rod Assembly
22032	Retainer
22035	Nut
22012	Mach Filter Bottle
34449	Air Cock Regulator Valve

Air Regulator

Maximum Working Pressure:
160 psi (1.1 MPa, 11 bar)

AIR REGULATOR

Part No. 1630

PART NO.	DESCRIPTION
10022	Adjusting Screw
10023	Screw
10003	Bonnet
10018	Washer Spring
10016	Pressure Spring
10019	Vibration Dampener
10015	Diaphragm
10008	Valve Body
10005	Valve Seat
10010	Valve
10006	Valve Spring
10002	Body
10013	Brass Screen

